



**Department  
of Health**

**Office of  
Health Insurance  
Programs**

# **Pathways to Becoming Compliant with CMS Conflict of Interest Requirements**

**Nursing Home Transition and Diversion (NHTD) Waiver Program**

**And**

**Traumatic Brain Injury (TBI) Waiver Program**

January 11, 2019

# Topics for Discussion

- Introductions
- NHTD and TBI Waiver Updates
- HCBS Final Rule
- CMS Conflict of Interest Requirements
- For Discussion: Potential Conflict of Interest Compliant Models

# NHTD and TBI Waiver Updates

- The TBI waiver renewal application has been approved by CMS through August 31, 2022.
- The NHTD waiver renewal application has been approved by CMS through June 30, 2023.
- Housing Payment Agent Contract
  - Through a competitive process, the contract has been awarded to Public Partnerships LLC.
  - Contract now includes both TBI and NHTD housing.
- DOH Team is currently updating NHTD and TBI program manuals and expects to distribute them to stakeholders for comment in February.

# NHTD and TBI Waiver Updates

- DOH is in the process of preparing a crosswalk of previous qualifications vs. currently approved qualifications which will be presented for stakeholder comment. DOH will schedule a work group meeting to discuss crosswalk and comments in the near future.
  - We will be seeking an amendment to grandfather in existing SC staff that do not meet new/current qualifications.
  - To potentially help with capacity for service coordination, CIC and ILST, DOH will be seeking to amend both NHTD and TBI applications to address provider qualifications.
- CMS has also been advised that DOH will seek an amendment to address service limit caps imposed on the TBI waiver where there are currently no provisions for exceptions (i.e., circumstances where DOH may approve authorizations above the limits).

# NHTD and TBI Waiver Updates

- The rate increase for TBI to address the Fair Labor Standards Act (FLSA) requirements, retroactive to October 13, 2015, is currently in review by CMS. The new rate will be implemented by the end of January. The rate increase for NHTD was implemented in July 2017.
- The minimum wage rate increase for TBI was submitted to CMS and is currently under review. Upon approval by CMS, NYSDOH will submit the same request to CMS for NHTD. This approach to submitting amendments for approval was requested by CMS.
- The minimum wage rate increases are submitted to the Division of Budget (DOB) and are pending approval.
- The minimum wage rate increase will include both 2018 and 2019 rate increments and will be included in the 2019 rate.

# Home and Community Based Services (HCBS) Final Rule

- Enacted effective March 17, 2014 – relates to the provision of HCBS authorized under 1915(c) and 1915(i) waiver authorities (latter includes CFCO).
- Three Key Components of the HCBS Final Rule:
  - Defines, describes and aligns home and community based **setting requirements**;
  - Defines **person-centered planning requirements**; and
  - Defines **conflict of interest provisions**.

More information on the HCBS Final Regulation can be found here:

<https://www.medicaid.gov/medicaid/hcbs/guidance/hcbs-final-regulation/index.html>

# HCBS Final Rule: Settings Requirements

- Establishes that HCBS must be delivered in settings that meet defined criteria (e.g., is integrated and supports access to the greater community, facilitates choice regarding services and supports and who provides them).
- In general, institutional settings and settings that have the qualities of an institutional setting do not qualify as compliant “home and community based settings”.
- See Appendix for more information about definitions for compliant settings.
- NYSDOH received CMS approval of its Statewide Transition Plan (STP) November 16, 2018 to become fully compliant with the settings rule by March 1, 2022.

The State’s Transition Plan can be found here:

[https://www.health.ny.gov/health\\_care/medicaid/redesign/home\\_community\\_based\\_settings.htm](https://www.health.ny.gov/health_care/medicaid/redesign/home_community_based_settings.htm)

# HCBS Final Rule: Settings Requirements

- What does this mean for NHTD and TBI Waivers?
  - This may result in assessment of structured day program sites and home visits in the natural course of service provision.
  - Additional activities will be needed by providers and the RRDCs to ensure compliance.
- DOH will be providing updates, information and additional guidance over the next couple of months.



# HCBS Final Rule: Person-Centered Service Planning Requirements

- What does this mean for the NHTD and TBI waivers?
  - NHTD and TBI are generally already compliant with person-centered service planning requirements.
  - DOH team will include person-centered planning requirement changes in their respective program manuals.

# CMS Conflict of Interest (COI) Requirements

- With much discussion, CMS agreed to extend the date for which the TBI and NHTD waivers must meet Conflict of Interest Requirements from January 1, 2019 to ***January 1, 2021.***
- DOH will submit a technical amendment to the waiver to make this change, effective January 1, 2019 – DOH and CMS are prioritizing the wage amendments.
- Our goal is work collaboratively with you (providers and stakeholders) and CMS, to explore and implement approaches that are compliant with COI and to the maximum extent possible preserve continuity of care, choice, provider stability, and capacity and access to services.
- As discussed later, we will need to work collaboratively under short timeframes to ensure there is sufficient time to ensure a smooth transition to COI compliance and that reflects the goals of above.

# HCBS Final Rule: Conflict of Interest (COI)

- ***Service Coordination*** activities must be independent of **direct waiver service provision**.
- Conflict occurs not just if the entity is a provider but if the entity:
  - Has an interest in a provider, or
  - Is employed by a provider.
- Requirements are located at [42 CFR 441.301\(c\)\(1\)\(vi\)](#).

# Conflict of Interest Defined

Providers of HCBS for the individual, or those who have an interest in or are employed by a provider of HCBS for the individual must ***not provide case management or develop the person-centered service plan.***

***Exception:*** Where the State can demonstrate that the only willing and qualified entity to provide case management and/or develop person-centered service plans in a geographic area also provides HCBS.

In these cases, the State must devise conflict of interest protections including separation of entity and provider functions within provider entities, which must be approved by CMS. Individuals must be provided with a clear and accessible alternative dispute resolution process.

***In addition, certain NHTD and TBI services are NOT subject to COI.***

Source: 42 CFR 441.301, Subpart (c)(1)(vi)

<b>NHTD Waiver Services</b>	<b>TBI Waiver Services</b>
-----------------------------	----------------------------

<b>Exempt Services</b>	<b>Non-Exempt Services</b>		<b>Exempt Services</b>	<b>Non-Exempt Services</b>	
<b>Assistive Technology (AT)</b>	Service Coordination	Independent Living Skills and Training	<b>Assistive Technology (AT)</b>	Service Coordination	Independent Living Skills and Training (ILST)
<b>Moving Assistance</b>	Community Integration Counselling (CIC)	Structured Day Program Services	<b>Community Transitional Services (CTS)</b>	Structured Day Program Services	Positive Behavioral Interventions and Support Services (PBIS)
<b>Community Transitional Services (CTS)</b>	Nutritional Counseling/Educational Services	Transportation Services	<b>Environmental Modifications (E-Mods)</b>	Substance Abuse Program Services	
<b>Congregate and Home Delivered Meals</b>	Peer Mentoring	Wellness Counselling		Transportation Services	
<b>Environmental Modifications (E-Mods)</b>	Positive Behavioral Interventions and Support Services (PBIS)	Home and Community Support Services (HCSS)		Community Integration Counselling (CIC)	
	Respiratory Therapy	Home Visits by Medical Personnel		Home and Community Support Services (HCSS)	
	Respite			Respite	

# Conflict of Interest Compliance

- The HCBS Final Rule is focused on the individual/participant not the provider.
- The individual may not receive service coordination (i.e., case management/planning) and direct waiver services from the **same** provider.
- Therefore, the rule does not necessarily preclude providers from offering both service coordination and other direct waiver services.

# COI Compliant

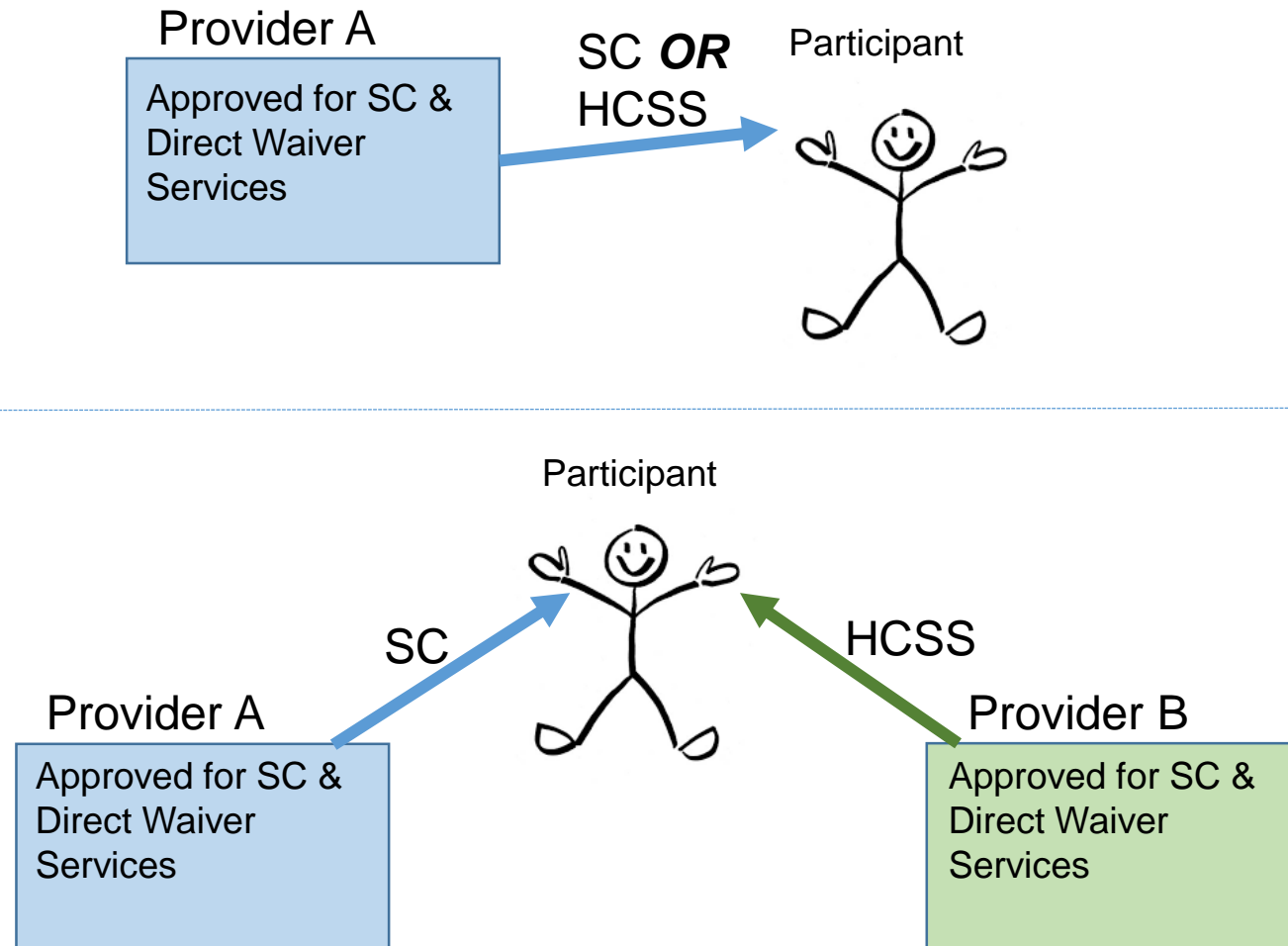

# Not COI Compliant

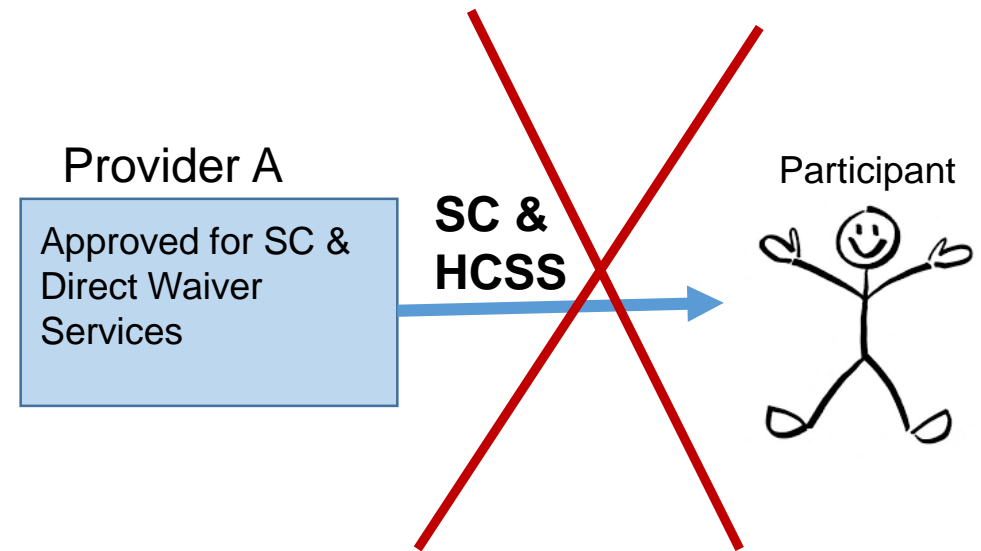

# How Many Participants are Currently Served?

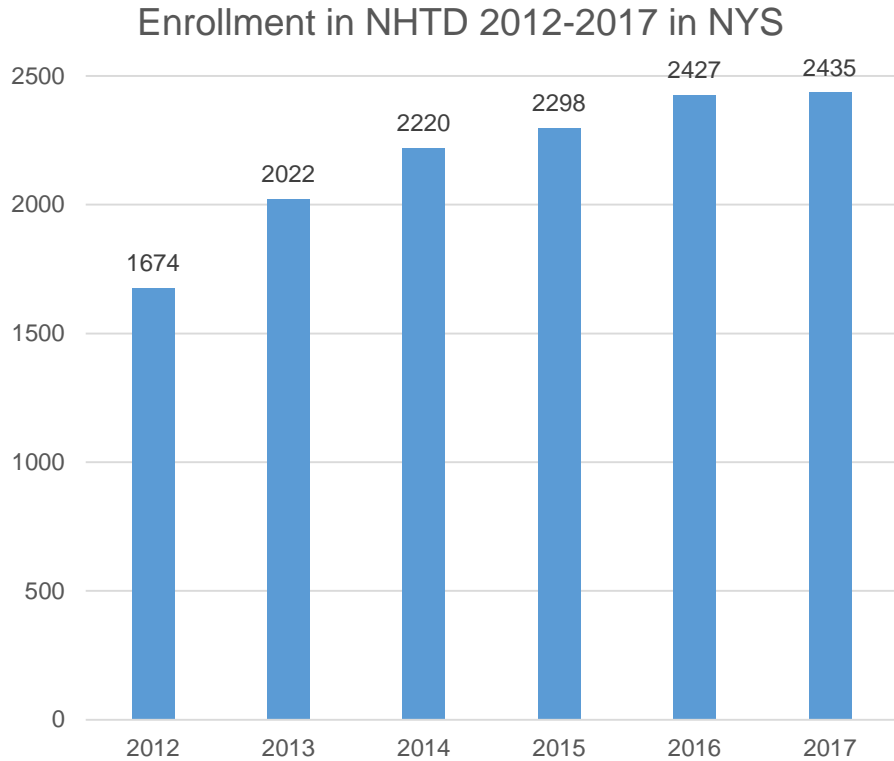

NHTD Housing Enrollment  
as of December 2018: 511

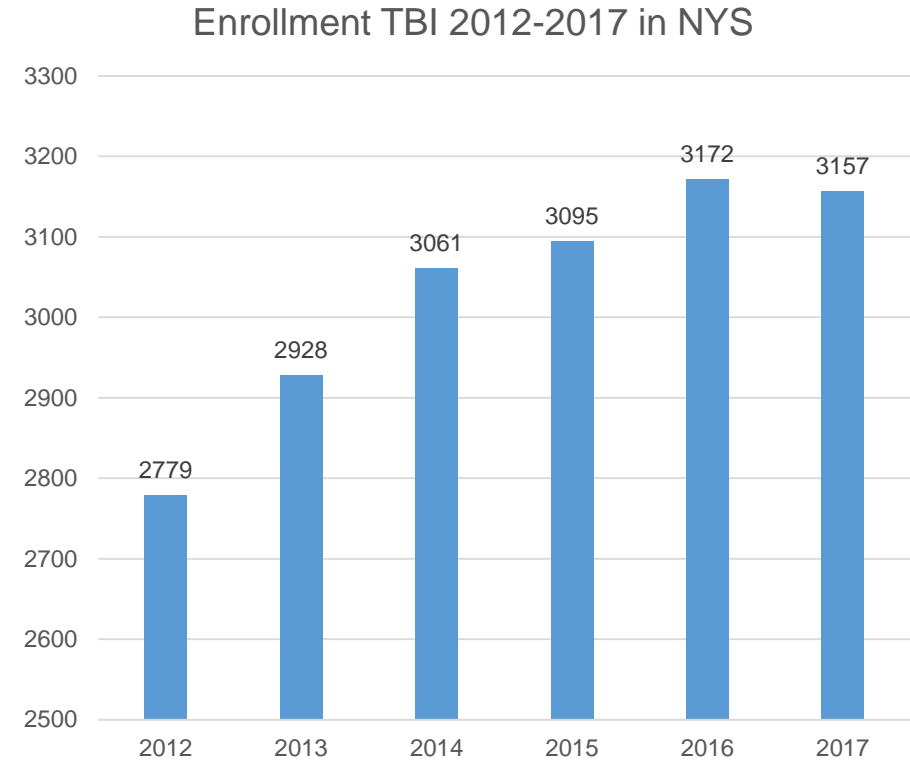

TBI Housing Enrollment  
as of December 2018: 856



# High Conflict of Interest Providers

- A high conflict of interest provider is one in which at least 50% of the Service Coordination caseload also receives HCSS from the agency.
- 20% of current TBI providers are considered to be “high conflict” providers.
- 30% of current NHTD providers are considered to be “high conflict” providers.
- It should be noted that TBI has at least one HCSS provider in every region that does not provide Service Coordination. NHTD has seven regions that meet this criterion. This data warrants further consideration.

Based on claims data.

# 69% of NHTD Service Coordination Providers Also Provide Other Direct Services

Region	NHTD 2018				
	Total # of Approved Providers	# of SC + Other Services (not exempt*) Providers	# of SC + Other Services (exempt*) Providers	# of SC only Providers	# Non-SC Services Only
Adirondack	23	15	1	0	7
Binghamton	26	18	2	2	4
Buffalo	13	8	0	0	5
Capital	21	12	0	0	9
Long Island	35	23	0	2	10
Lower Hudson Valley	35	24	2	0	9
New York City	38	31	1	0	6
Rochester	25	19	1	1	4
Syracuse	20	13	0	0	7
<b>Total</b>	<b>236</b>	<b>163</b>	<b>7</b>	<b>5</b>	<b>61</b>

\*Exempt Services include: AT, CTS, Moving Assistance, Congregate/Home Delivered Meals and e-Mods/Vehicle Mods

Source: Conflict of Interest Compliance Implementation Plans

# 67% of TBI Service Coordination Providers Also Provide Other Direct Services

TBI 2018					
Region	Total # of Approved Providers	# of SC + Other Services (not exempt*) Providers	# of SC + Other Services (exempt*) Providers	# of SC only Providers	# Non-SC Services Only
Adirondack	27	17	0	0	10
Binghamton	34	21	1	2	10
Buffalo	18	11	0	0	7
Capital	25	12	0	0	13
Long Island	36	22	1	2	11
Lower Hudson Valley	36	28	0	0	8
New York City	36	30	0	0	6
Rochester	23	19	0	1	3
Syracuse	32	18	0	0	14
<b>Total</b>	<b>267</b>	<b>178</b>	<b>2</b>	<b>5</b>	<b>82</b>

\*Exempt Services include: AT, CTS, and e-Mods/Vehicle Mods

Source: Conflict of Interest Compliance Implementation Plans

# Potential Exemptions from COI

- An exemption may be granted if the State can demonstrate that *the only willing and qualified entity* to provide case management and/or develop person-centered service plans in a geographic area also provides HCBS.
- For example:
  - Rural/frontier area "naturally" limits pool of available entities;
  - Cultural considerations; and
  - Linguistic considerations.
- CMS requires supporting documentation for any request for exemption.

# Recent COI Survey

- The Conflict of Interest Survey via SurveyMonkey© was distributed on January 3, 2019.
- The survey collects county data by waiver services, including Service Coordination, and inquires about capacity to serve new waiver participants.
- This data will help us determine if there are exemptions under the “only willing and qualified” provider criteria.
- As of January 9, 2019:
  - NHTD received 47 responses
  - TBI received 52 responses
  - Average survey completion time: 4 - 7 minutes
  - Not enough surveys have been completed for the data to generate a definitive analysis.

# Considerations for Developing Potential COI Compliant Service Models

- HCBS providers cannot provide case management or person-centered planning for people on their caseload.
  - Under our current waivers, both functions (case management and person-centered planning) above fall under Service Coordination.
- If there is only one willing and qualified HCBS provider in a geographic region, that HCBS provider may provide case management to and/or develop the person-centered plan for people on their caseload as long as conflict of interest protections are in place.
- CMS has approved the State's request to exempt Assistive Technology, Environmental Modifications, Vehicle Modifications, Moving Assistance and Congregate/Home Delivered Meals from COI requirements. Providers who offer Service Coordination may also provide these services to the same participants.

# Considerations for Developing Potential COI Compliant Service Models

- For the NHTD and TBI Waivers, the State is obligated to:
  - Offer informed choice regarding services and supports that the participant receives and from whom;
  - Include a mechanism for the participant to request updates and amendments to their service plan;
  - Reflect the cultural consideration of the individual;
  - Ensure continuity of care;
  - Provide necessary information and support to ensure the individual directs the person-centered planning process; and
  - Provide services in an HCBS-compliant setting.

# Potential Service Models

- **Service Coordination separation model\***

- Providers continue to provide multiple services, but cannot provide service coordination and other direct waiver services to the same individual.
  - Functions of Service Coordinators (SCs) may remain the same.
  - An individual's SC cannot be employed by a provider who is also offering direct waiver services to that individual.
  - Service Coordination only providers and those who offer Service Coordination and other exempt services may continue business as usual.
  - DOH/RRDC maintains authority over provider designation and final plan approval.

Example: ABC Provider offers Service Coordination to Janet. Janet also needs HCSS. ABC Provider cannot provide HCSS to Janet because they are already providing Service Coordination. ABC Provider can continue to provide other waiver services, just not to Janet.

\*Cultural and rural exemptions still apply.



# Potential Service Models

- **Statewide organization model\***

- A statewide organization provides Service Coordination only.
  - Service Coordination provider enrollment is limited to statewide Service Coordination agency/agencies.
  - Service Coordination only providers and those who offer Service Coordination and other exempt services may continue business as usual.
  - The provider(s) offer no other direct waiver services.

Example: Jordan is applying for NHTD waiver services. He selects DEFCo as his Service Coordination provider. DEFCo is approved statewide and connects Jordan with a conflict-free SC in his region who he meets with to develop his person-centered service plan. DEFCo provides no other direct waiver services.

\*Cultural and rural exemptions still apply

# Discussion and Other Suggestions for COI Compliant Models?

# Timeline for Implementation

- The Corrective Action Plan (CAP) is the formal agreement with CMS on the activities and timelines the state will engage in to meet the COI requirements. The approved CAP authorizes the state to continue providing services pending full COI compliance.
- The NHTD and TBI waivers must be fully compliant (implemented and operational) with Conflict of Interest Provisions by January 1, 2021.
- Because we are under extension and not in compliance, CMS has required that DOH submit a revised CAP to reflect the January 1, 2021 date for compliance which is now under CMS review.

<b>Timeline to Compliance - The Dates Below are Subject to CMS Approval</b>	
<b><u>Compliance Readiness Action</u></b>	<b><u>Due Date</u></b>
1. Stakeholder workgroup/service model development period <ul style="list-style-type: none"> <li>a. Service model selection</li> <li><b>b. CMS has expressed its desire to dedicate more time to implementation and procedural development rather than focus on model discussion/development</b></li> <li>c. Steps to service model operationalization                             <ul style="list-style-type: none"> <li>i. Ensuring continuity of care, provider stability, participant choice</li> </ul> </li> </ul>	Begins January 2019
2. Ongoing CAP meetings with CMS	Ongoing
3. Submission and approval of final model to CMS <ul style="list-style-type: none"> <li>a. Post model for public comment</li> </ul>	<b>4/2019</b> 30 days
4. Develop and implement transition steps <ul style="list-style-type: none"> <li>a. Provider pool development                             <ul style="list-style-type: none"> <li>i. Rate setting/rate code development</li> <li>ii. Provider enrollment</li> </ul> </li> <li>b. Policy creation and dissemination                             <ul style="list-style-type: none"> <li>i. Protocol development/program manual updates</li> </ul> </li> </ul>	4/2019-7/2019

<b><i>Timeline to Compliance - The Dates Below are Subject to CMS Approval</i></b>		
	<b><u>Compliance Readiness Action</u></b>	<b><u>Due Date</u></b>
5.	Communication of final transition plan and CAP status	7/2019
6.	Federal public notice and public comment	7/2019-8/2019
7.	Submission and approval of waiver amendments	9/2019-12/2019
8.	Systems and edits development and implementation (eMedNY)	4/2019-1/2021
9.	Final transition and full compliance with COI	1/2020-1/2021

# Next Steps

- Reconvene on:
  - Results of Survey
  - Stakeholder Feedback
  - Meeting Date in February

# *Appendix*

January 11, 2019

# HCBS Settings Requirements

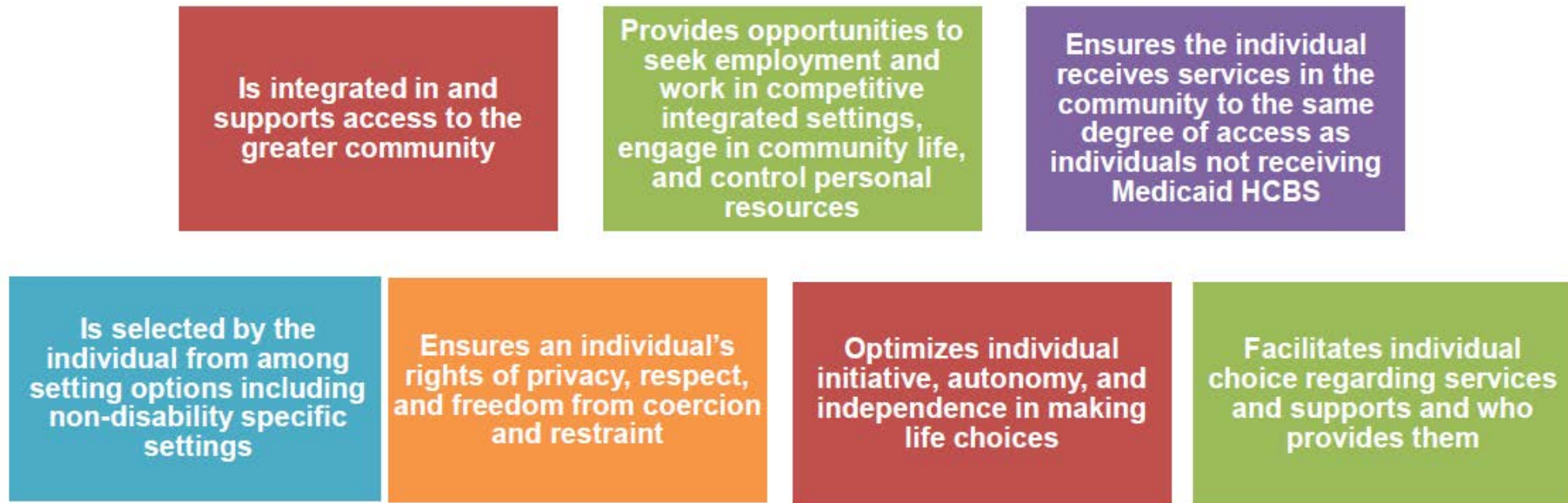

\*There are additional standards for provider-owned and/or controlled settings



# Provider-Owned and Controlled Standards

In such settings *where the HCBS provider owns or operates the HCBS recipient's residential service*, the additional standards below apply:

The additional standards for *residential* settings are:

- Individuals in residential units have legally enforceable agreements giving them the same protections and responsibilities as any tenant living in that jurisdiction
- Privacy in sleeping or living unit
- Units have lockable entrance doors
- The individual served and appropriate staff have keys/codes to doors
- There is a choice of roommates in shared units
- Freedom to furnish and decorate sleeping or living units

The additional standards for *all settings* are:

- Freedom and support to control one's own schedule and activities
- Access to food and visitors at any time
- The setting is physically accessible to the individual (\*not modifiable)

# NYSDOH Waiver Unit

*Contact us:*

[waivertransition@health.ny.gov](mailto:waivertransition@health.ny.gov)